

IR320 Infrared Receiver Specifications:

Specifications

Infrared carrier frequency:	25-65 kHz
Indoor reception range:	100 feet (30 meters) max.
Nominal reception angle:	50 degrees off axis
Maximum wire length:	1000' (300m) or even more with larger gauge wire
Wire requirements:	3 conductors, minimum 24-gauge to 200'; 22-gauge up to 500'; 20-gauge to 1000'
Power requirements:	12VDC, 40mA
Dimensions:	15/19" x 3/8" x 1/2" h (24 mm x 10 mm x 13mm h)

Requires 12VDC power supply, emitter(s) and a connection block.

Warranty

Knoll Systems warrants its products (with certain exceptions) sold in the USA and Canada by authorized Knoll dealers to be free of defects in materials and workmanship. This warranty extends for three full years from the date of purchase by the original consumer. Any products returned to Knoll Systems and found to be defective by Knoll Systems within the warranty period will be repaired or replaced at Knoll Systems option, at no charge. Knoll Systems will not be responsible for the actual cost of installation or removal of the product, nor for any incidental or consequential damages. Some states do not allow the exclusion or limitation of incidental or consequential damages, so the above limitation may not apply to you. This warranty gives you specific legal rights. You may have additional legal rights that vary from state-to-state.

Knoll Systems www.knollsystems.com
145 Tye Drive Point Roberts, WA 98281
14-7163 Vantage Way, Delta BC V4G 1N1
Telephone: (604) 940-1689, Fax (855) 734-3363
www.knollsystems.com
Made in Canada Knoll Systems All Rights Reserved



IR320

Micro Infrared Receiver Installation Instructions v1.0

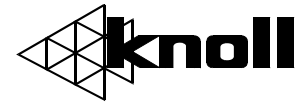

Warning: To be installed and/or used in accordance with appropriate electrical codes and regulations.

Introduction: Thank you for your purchase of a Knoll IR320 infrared receiver. This receiver features the ability to pick up a remote control infrared signal and relay it on wires to the inside of a cupboard or to another location up to 1000' (or more).

Actual size

Features:

- Very small design.
- More forgiving than previous designs and can work short distances in **direct sunlight**.
- Will relay almost all remote control types.
- Requires very little power. Suggest using Knoll PS1205 for up to ten IR320's.
- Up to ten Knoll infrared receivers can be connected in a single system.
- Available in black, white and silver colors.
- Connects with a three wire connector or 3.5mm plug.



Installation Tips

1. Follow all local electrical & building code requirements.
2. The IR320 is usually mounted to the wall or cabinet using the included double sided tape. For easy installation and to ensure reliability, it is suggested to use a Knoll PS1205 power supply, Knoll single or dual emitters and a Knoll connection block or hub.

3. If longer wires are required for the IR320, solid or stranded, shielded or unshielded with a minimum of 28-gauge for runs under 200', 22-gauge for runs under 500' and 20-gauge for runs up to 1000'. Wires can be looped from IR320 to IR320 or home run. Home wire runs normally offer more reliability and future flexibility.

4. IR320s can be mixed and matched in larger systems with up to 10 Knoll infrared receivers.

5. When connecting multiple Knoll infrared receivers to the IR155 detachable connector, make sure the infrared receivers are wired in parallel only. For a single IR320 connected to the IR155 infrared hub the red plug can be connected to the IR155 red jack. If the wire length needed is longer or multiple infrared receivers are to be connected use the following procedure: Connect the infrared receiver(s) **12V**, **GND** and **SIG** terminals to the corresponding IR155 screw terminals. Prepare the wire leads to and from the IR receivers by stripping about 1/4" of the insulation from each of the three leads. Twist the strands tightly together so that they do not stick out of the connector and cause a short circuit. Strictly observe polarity.

IR320 wiring identification

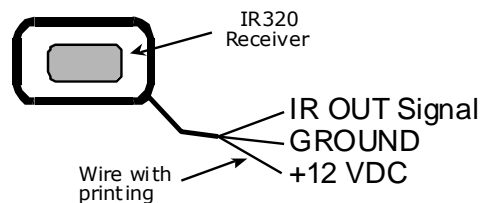

6. Next, plug the single or dual emitter(s) into the Knoll connection block and position and attach the emitter output to the source components infrared receiver window.

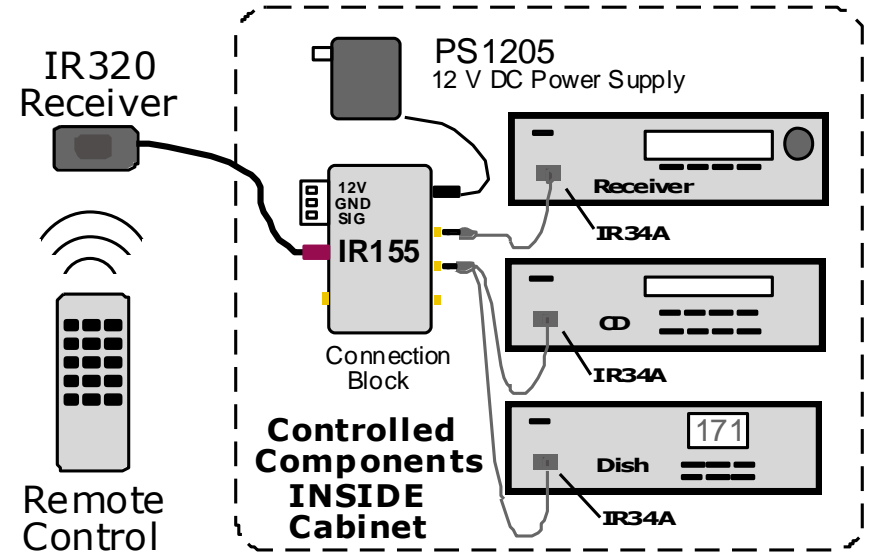

IR320 system typical layout

7. Plug in the power supply. The Knoll PS1205 can power one to ten infrared receivers, one connection block and one to four single or dual emitters.

8. The infrared system is usually left plugged in all the time (to an unswitched outlet) as it uses very little power.

9. Test the infrared system to see if it is working properly. Bright sunlight and passive infrared security systems can lower the distance that remote controls can work with an IR320 receiver.

If you have any questions or concerns, please call and ask for infrared technical support at 1 800 566 5579. The help line is open from 7:30 a.m. to 4:00 p.m., Monday to Friday, Pacific time.